



TECHNOLOGY BROCHURE

Oil condensing technology

**VITOLADENS**

**VITORONDENS**

**Heating with oil**

Proven technology  
with high efficiency



This brochure contains extensive information about convenient heat generation with oil. When you purchase a Viessmann condensing boiler, you make an active contribution towards utilising resources efficiently and saving energy. The efficiency of these boilers is unbeatably high, with up to 98 percent of the fuel oil used converted into heat.

Viessmann oil condensing boilers come prepared for the future. They are supplied ready equipped to accommodate a changeover from fossil oil to fuel oil mixed with a certain percentage of bio-oil, and so can also be used with renewable fuel types.

The new heating system can also be combined with free solar energy, as all the boilers are designed to allow connection to a solar thermal system for DHW heating or central heating backup.

Viessmann system design guarantees that all components work together perfectly, right down to the convenient control unit that meets your every demand.

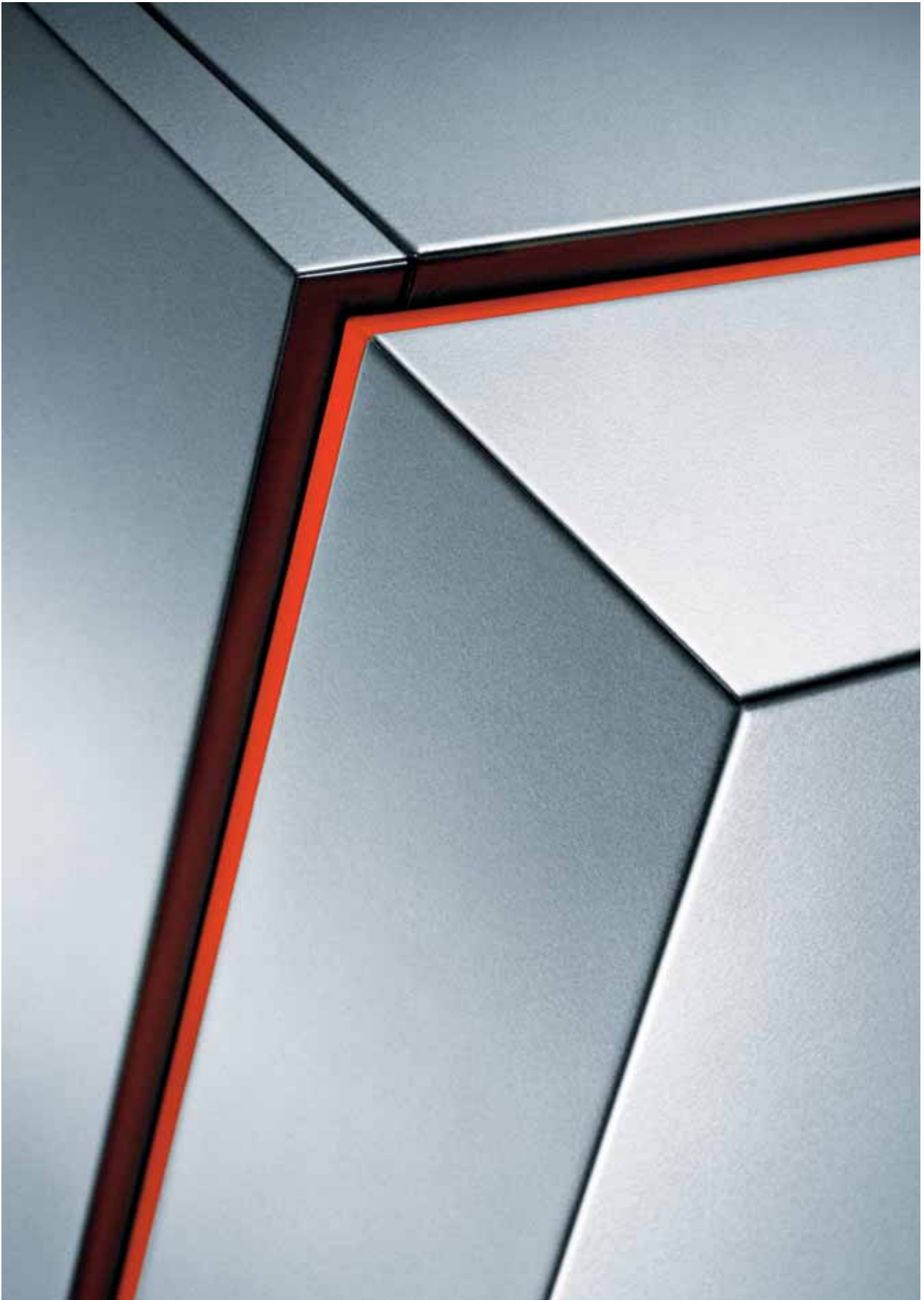



6

## 6 BOILER REPLACEMENT FOR REDUCED ENERGY BILLS

Find out why it is worth modernising a heating system now, to make an active contribution towards protecting the climate and using less fossil fuels.



10

## 10 CONVENIENT AND ENERGY EFFICIENT CONTROL

The ViCare app offers new possibilities for operating heating systems via the internet. The design of the ViCare graphic interface has been kept simple deliberately. The result: completely intuitive heating system operation.



12

## 12 EFFICIENT AND PROVEN OVER DECADES

The oil condensing boilers from the Vitoldens and Vitorondens series offer the best energy utilisation along with economical consumption.



26

## 26 A PERFECT MATCH: SYSTEM TECHNOLOGY

System technology from Viessmann perfects the new heating system: Vitotronic control units and VitoCell DHW cylinders, as well as solar technology, for cost effective DHW heating and central heating backup.



28

## 28 SERVICE THAT COVERS EVERY ASPECT OF HEATING

Viessmann trade partners can provide comprehensive advice about tailor-made heating technology, available subsidies and finance options.



30

## 30 THE COMPANY

The power of innovation: a family business for three generations, Viessmann offers state of the art technology and takes its responsibilities seriously.



Viessmann works continually to develop new, environmentally responsible solutions, resulting in eco-friendly, cost effective and efficient heating systems.

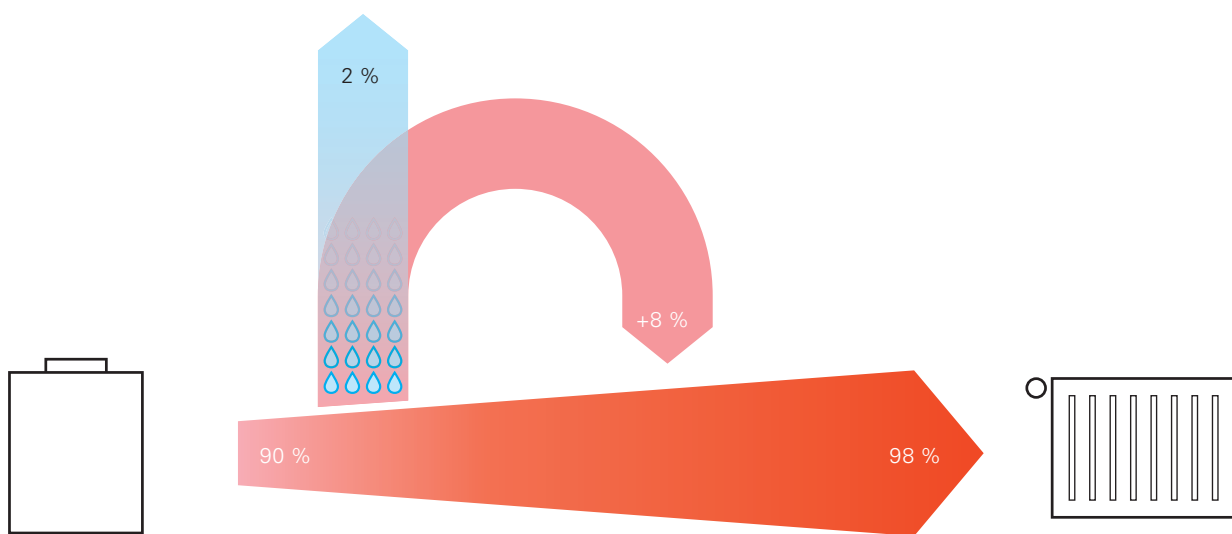

**How condensing technology works:**

Viessmann gas boilers and condensing technology turn up to 98 percent of the energy spent into heat. Through the condensation of water vapour contained in flue gas, additional heat is released which is returned to the heating system. This improves efficiency, cuts heating bills and reduces the environmental impact.

# Plenty of good reasons for modernising heating systems using efficient oil condensing technology

## **Replacing old boilers reduces energy bills by up to 35 percent**

In Germany alone, there are still around two million heating systems in use today that are more than 25 years old. Their owners are often completely unaware of how much money they are wasting on energy, which is lost through the chimney as unused heat. Furthermore, these old systems have an impact on our climate through unnecessary CO<sub>2</sub> emissions which contribute to global warming.

## **Saving energy**

By promptly replacing these systems with highly efficient condensing boilers combined with solar technology, end users could cut their energy consumption by up to 35 percent. This would translate into ten percent of Germany's total energy needs, with annual CO<sub>2</sub> emissions simultaneously being reduced by 54 million tonnes.

## **Central heating backup with solar energy**

The free energy from the sun is still not used enough for DHW heating and central heating backup. Particularly when modernising a heating system or replacing a boiler, it goes almost without saying that a solar thermal system should be incorporated as well. These systems are subsidised by public grants, and will only take a few years to pay for themselves because of the large amount of energy they save.



The Viessmann Building Energy Economy Check provides all the answers to key questions about modernising a heating system. Only a few details need to be entered via a PC or tablet.

## **How to save with condensing technology**

Condensing technology utilises not only heat from the combustion of fuel oil or gas, but also heat that escapes unused with conventional heating technology.

Condensing boilers extract almost all of the heat in flue gases and convert it into additional heating energy. To do this, Viessmann condensing boilers are equipped with stainless steel Inox-Radial heat exchangers. These cool the flue gases before they are routed into the chimney, to the extent that the water vapour they contain is

deliberately condensed. Additional heat is thus released and transferred into the heating system.

With this technology, condensing boilers achieve a standard seasonal efficiency [to DIN] of up to 98 percent, and so are particularly energy efficient. This function not only saves valuable energy, but also protects the environment through significantly lower CO<sub>2</sub> emissions.

[www.check-energiesparen.de](http://www.check-energiesparen.de)



▲ A milestone in innovative heating technology: the use of high alloy stainless steel in the Inox-Radial heat exchanger. ▲



# Viessmann has regularly set new milestones in the development of advanced heating technology throughout its 100 year history

## **Viessmann sets standards in efficiency, energy consumption and design**

Viessmann has been a pacemaker in the heating technology industry for decades. Ongoing innovation has raised the efficiency in converting energy into heat to the limits of that which is currently technically possible. At the same time, it has been possible to drastically reduce the energy consumption levels and CO<sub>2</sub> emissions of all boilers.

## **The biferral composite heating surface**

The invention of the duplex biferral composite heating surface in the 1970s was a quantum leap for energy efficient heating. Even today it is synonymous with high operational reliability and a long service life. This heating surface is an important component of the successful Vitola and Vitoladens oil boilers, and has been installed in around two million Viessmann boilers.

## **Inox-Radial heat exchanger**

All Viessmann oil condensing boilers are equipped with the stainless steel Inox-Radial heat exchanger. This indestructible technology brings with it high efficiency of 98 percent, plus safe and efficient operation during its long service life. Oil condensing boilers are already designed to meet future standards, as they can be fired with different types of fuel oil and partial mixtures of bio-oil.



In the Vitoladens 300-C oil condensing boiler, the benefits of the biferral composite heating surface are coupled with a directly connected stainless steel Inox-Radial heat exchanger. This combines high levels of efficiency with a stylishly compact and appealing design.

## **Award-winning design**

For Viessmann, top technology and an attractive design go hand in hand. The company has received more than 40 significant design awards from all over the world for its products in recent years. Viessmann heat generators have won the renowned Red Dot Design Award twenty times.

Highly efficient technology "Made in Germany" in an award-winning design: the Vitoladens 300-C has won the Red Dot Design Award.

## **10 year guarantee**

on stainless steel heat exchangers for oil or gas condensing boilers up to 150 kW

For conditions, see [www.viessmann.de/garantie](http://www.viessmann.de/garantie)

▲ The quick and easy way to save energy and enjoy the benefits of convenience and reassurance. ▲



The ViCare app offers new possibilities for controlling heating systems via the internet. The design of the ViCare graphic interface has been kept simple, enabling completely intuitive heating system operation.

#### **Save energy automatically**

The system is designed to control one heating circuit. You can set the required room temperature via the touchscreen, and switch between standard and party mode ("Extended heating") with a single tap.

When leaving the house ("Away"), it takes just one command to reduce the heating system temperature and save energy. Anyone wanting to program different switching times for each day will appreciate the assistant function.

A separate button on the home screen also shows numerous tips for saving energy.

#### **System status at a glance**

Green for go – the user can see at a glance whether their heating system is working as it should. Yellow lets you know about a pending service and red automatically offers to contact the contractor.

To enable this function, simply store the contact details of the contractor. Of course, the system user has the final decision on whether to allow the contractor to monitor their heating system using the specially developed Vitoguide app.

Vitoconnect is the interface between the heat generator and ViCare. It is connected directly to the Vitotronic control unit via a cable. A plug-in power supply unit is included in the standard delivery. The small adaptor, measuring only 10 x 10 cm, is designed for wall mounting.

Connect the module to the internet and register via plug & play. Simply scan the supplied QR code using a smartphone.

Vitoconnect is compatible with mobile devices and operating systems iOS 8.0 and Android 4.4 or higher. Control LEDs indicate data communication between the heat generator and the internet.

### Explanation in brief

ViCare accesses the Vitoconnect internet interface to control the heat generator. Once the system user has given their consent, the contractor can use Vitoguide to keep a constant eye on their customer's system.



Vitoconnect with sockets for the plug-in power supply unit (left) and data connection

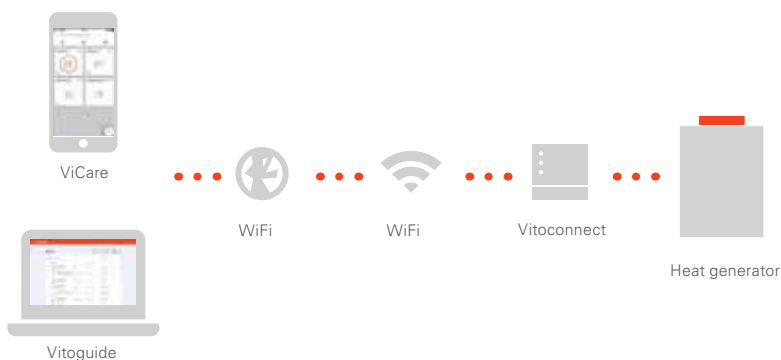

### 5 year guarantee

with system web connection/ connectivity

For conditions, see [www.viessmann.de/garantie](http://www.viessmann.de/garantie)

### REASSURANCE

Warmth and reassurance:



- + Green for go – see at a glance whether everything is OK
- + Be informed about a pending service
- + Direct access to the contractor's saved contact details



### ECONOMY

Simply set your preferred temperature – save costs when you're not at home:

- + Straightforward, convenient operation of the heating system
- + Record your daily routine and automatically save on energy costs
- + Set standard functions at the tap of a button on your smartphone

### SUPPORT

A direct link to the contractor – just in case:



- + Simply enter the contact details of the contractor
- + Quick and effective assistance – the contractor has all of the important information
- + All-inclusive carefree safety and maintenance package



Download on the App Store

GET IT ON Google Play

Simply download the app and tap "Discover ViCare" on the app's start screen – and off you go, with no need for an actual heat generator or internet connection.



## Heat economically, cleanly and efficiently with oil condensing boilers

Viessmann oil condensing technology is one of the cleanest and most efficient options for heat generation, with efficiency of 98 percent. Latent heat, which is normally wasted by old, conventional boilers, is recovered through the condensation of the hot gases.

### **Setting standards for oil condensing technology: Vitoladens and Vitorondens**

There are lots of reasons for choosing an oil condensing boiler:

- Highly reliable
- Long service life
- Convenient DHW and central heating
- Cost savings through economical energy consumption
- A perfect match for solar thermal technology
- Sustainability through the proportional use of bio-oil



### **VITOLADENS 300-C**

Oil condensing boilers  
10.3 to 28.9 kW

**PAGES 14 – 17**



### **VITOLADENS 300-T**

Oil condensing boilers  
35.4 to 53.7 kW

**PAGES 18 – 19**



### **VITORONDENS 200-T**

Oil condensing boilers  
20.2 to 107.3 kW

**PAGES 20 – 23**



# Oil condensing technology with an outstanding price/performance ratio – extremely compact and ideal for modernisation projects

The Vitoladens 300-C and Vitoladens 300-T are an unbeatable duo when it comes to modernising an older heating system. These boilers are amongst the most popular products in their class.

They are the product of Viessmann's many years of experience. The company regularly attracts attention with new milestones in heating technology.

In both Vitoladens models, the biferral composite heating surface and downstream stainless steel Inox-Radial heat exchanger play a major role in ensuring that the energy used is converted into heat with virtually no losses and efficiency of up to 98 percent.

## TAKE ADVANTAGE OF THESE BENEFITS

- + Highly efficient and compact floorstanding oil condensing boilers
- + Output range from 10.3 to 53.7 kW
- + Standard seasonal efficiency [to DIN] up to 98 % ( $H_g$ ) [gross cv]
- + Corrosion-resistant Inox-Radial heat exchanger made from stainless steel
- + Clean combustion thanks to the Vitoflame 300 blue flame oil burner
- + Easy to use Vitotronic 200 control unit with plain text and graphic display
- + Flexible siting through room sealed or open flue operation
- + All commercially available low sulphur EL fuel oils can be used – including low sulphur EL fuel oil DIN 51603-6-EL A Bio 10 with blends of up to 10 % bio-components (FAME)
- + Web-enabled through Vitoconnect (accessories) for operation and service via Viessmann apps



The "Design Zentrum Nordrhein-Westfalen" bestowed the prestigious Red Dot Award on the Vitoladens 300-C for its design.



International  
Forum  
Design

DESIGN PLUS  
Sanitär Heizung Klima



The Vitoladens 300-T has won several coveted design awards.



Vitoladens 300-C with Vitocell 300-H  
DHW cylinder in a matching design

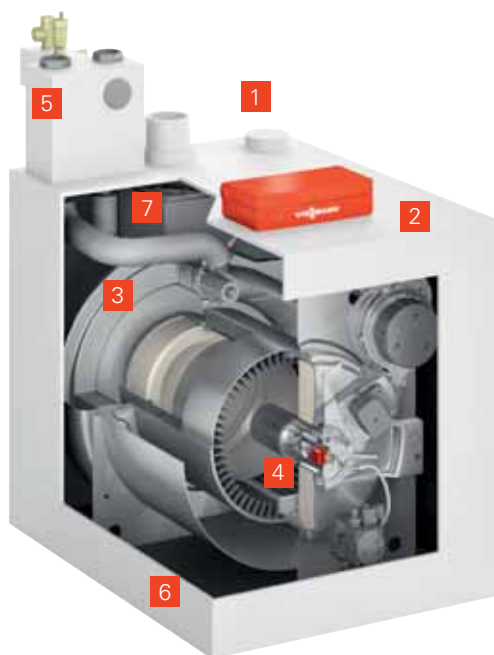

#### VITOLADENS 300-C

- 1** Flue outlet and ventilation air inlet at the top
- 2** Vitotronic control unit
- 3** Integral Inox-Radial heat exchanger made from stainless steel
- 4** Compact blue flame burner
- 5** Safety assembly included in standard delivery
- 6** Biferral composite heating surface
- 7** Integral silencer



**VITOLADENS 300-C**  
10.3 to 28.9 kW

Investing in a Vitoladens 300-C soon pays off. It uses far less fuel oil than older boilers on account of its high efficiency.

With its compact dimensions, it takes up a minimum amount of space and can be set up for room sealed or open flue operation. It is therefore well suited to either a basement or utility room and ideal for heating system renewal. In new build, valuable space can then be used for other purposes.

**Powerful and efficient**

With three output stages up to 28.9 kW, the Vitoladens 300-C oil condensing boiler is suitable for detached or two-family houses. The two-stage or modulating Compact blue flame burner with integral silencer matches its output to the prevailing heat demand, ensuring maximum energy efficiency.

**Highly effective  
heat exchanger**

At the core of this condensing boiler lies a corrosion-resistant stainless steel Inox-Radial heat exchanger. In direct connection with the biferral composite heating surface, the energy used is converted to heat with practically no losses and up to 98 percent efficiency. This extremely economical usage of valuable fuel oil also results in reduced CO<sub>2</sub> emissions.

**Combination with  
solar technology**

An advanced heating system should include innovative solar thermal technology to utilise free energy from the sun. Viessmann offers a system for this which is compatible with the Vitoladens 300-C.

**Easy to install  
and combine**

All connections on the Vitoladens 300-C are at the top. It is prefitted at the factory, and takes little time to install on site. Adapted and extended transport accessories make handling easier. Where space is tight, the side panels and burner can be removed.



Stainless steel Inox-Radial heat exchanger guarantees the highest levels of efficiency and a long service life.



Vitotronic control unit with clear user prompts

**TAKE ADVANTAGE OF THESE BENEFITS**

- + Oil condensing boiler in the output range 10.3 to 28.9 kW
- + Maximum energy utilisation with minimum dimensions
- + Biferral composite heating surface with directly connected stainless steel Inox-Radial heat exchanger
- + Two-stage or modulating Compact blue flame burner for open flue or room sealed operation
- + Quiet operation through integral silencer
- + Fast and flexible handling and siting, even in tight spaces
- + Safety assembly included in standard delivery

For specification, see page 24



Vitoladens 300-T with adjacent Vitocell 100-V  
DHW cylinder and fuel oil tanks

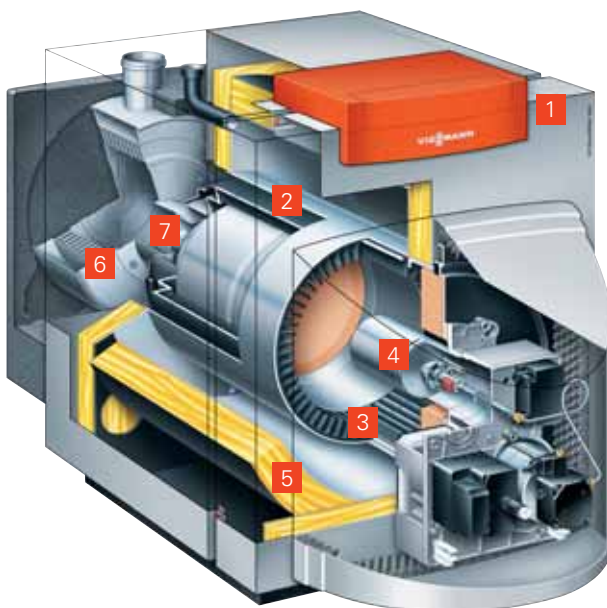

#### VITOLADENS 300-T

- 1** Vitotronic control unit
- 2** Wide water galleries and large water capacity
- 3** Biferral cast iron and steel composite heating surface
- 4** Vitoflame 300 Unit blue flame oil burner
- 5** Highly effective thermal insulation
- 6** Inox-Radial heat exchanger
- 7** Integral silencer

**VITOLADENS 300-T**  
35.4 to 53.7 kW

The Vitoladens 300-T is the world's most popular oil condensing boiler. This is thanks to its particularly attractive price, excellent operational reliability and long service life.

Not only is it economical in its consumption of valuable fuel oil, but maintenance costs are also kept low through the use of high quality materials and proven components. In addition, the Vitoflame 300 Unit blue flame oil burner stands for particularly clean, environmentally responsible and efficient combustion.

**Inox-Radial heat exchanger made from stainless steel**

The two-stage heat recovery of the Vitoladens 300-T comprises the proven biferral composite heating surface and the corrosion-resistant stainless steel Inox-Radial heat exchanger, installed downstream of the boiler.

This design ensures that combustion and condensation occur in physically separate locations and the combustion gases condense without leaving any residues behind. In practice, this means longer-than-average service intervals for cleaning the combustion chamber and significantly lower maintenance costs.

**Flexible application**

In the output range from 35.4 to 53.7 kW, the Vitoladens 300-T covers many applications – from detached houses and apartment buildings to smaller commercial operations.

**Installation room**

There is no need for a conventional boiler room for installation. This oil condensing boiler can simply be fitted in a corner of the basement or laundry room.



Biferral cast iron and steel composite heating surface



Vitoflame 300 Unit blue flame oil burner for particularly clean, environmentally responsible combustion

**TAKE ADVANTAGE OF THESE BENEFITS**

- + Oil condensing boiler in the output range 35.4 to 53.7 kW
- + Durable biferral composite heating surface, proven in millions of boilers
- + Corrosion-resistant Inox-Radial heat exchanger made from stainless steel
- + Easy accessibility of the heat exchanger surfaces for cleaning
- + Quiet operation through integral silencer

For specification, see page 24



## Compact, affordable cast iron oil condensing boiler for modernisation projects

The strengths of the Vitorondens 200-T lie in its suitability for the modernisation of apartment buildings and commercial premises. Its features are impressive, with compact dimensions, durable Eutectoplex heating surface and stainless steel Inox-Radial heat exchanger installed downstream of the boiler.

Combining the durable Eutectoplex heating surface with the downstream Inox-Radial heat exchanger made from stainless steel separates combustion and condensation effectively. The benefit lies in the fact that the combustion residues remain in the combustion chamber, whilst the combustion gases can condense in the heat exchanger without leaving any residues behind.



Inox-Radial heat exchanger – durable and efficient

### 10 year guarantee

on stainless steel heat exchangers for oil or gas condensing boilers up to 150 kW

For conditions, see [www.viessmann.de/garantie](http://www.viessmann.de/garantie)

### TAKE ADVANTAGE OF THESE BENEFITS

- + Affordable cast iron oil condensing boiler for modernisation projects
- + Standard seasonal efficiency [to DIN]: up to 97 % (H<sub>g</sub>) [gross cv]
- + Proven components (e.g. Eutectoplex heating surface) for high operational reliability and a long service life
- + Downstream, self-cleaning Inox-Radial heat exchanger made from stainless steel
- + Clean combustion thanks to the Vitoflame 300 blue flame oil burner
- + JetFlow system for optimum heating water distribution
- + Flexible installation through room sealed (up to 53.7 kW) or open flue operation
- + Quiet operation through external flue gas silencer option
- + Easy to operate Vitotronic control unit with plain text and graphic display
- + All commercially available EL fuel oils can be used. Also for low sulphur EL fuel oil DIN 51603-6 EL A Bio 10: with blends of up to 10 % bio-components (FAME)
- + Time saved during installation, as thermal insulation and the control unit are prefitted on the Vitorondens 200-T (up to 53.7 kW)
- + Easy handling as the Vitorondens 200-T (from 67.6 to 107.3 kW) components are delivered separately. The boiler body is delivered as a block – thermal insulation, downstream heat exchanger and control unit are fitted on site
- + Web-enabled through Vitoconnect (accessories) for operation and service via Viessmann app



Vitorondens 200-T with adjacent  
Vitocell DHW cylinder

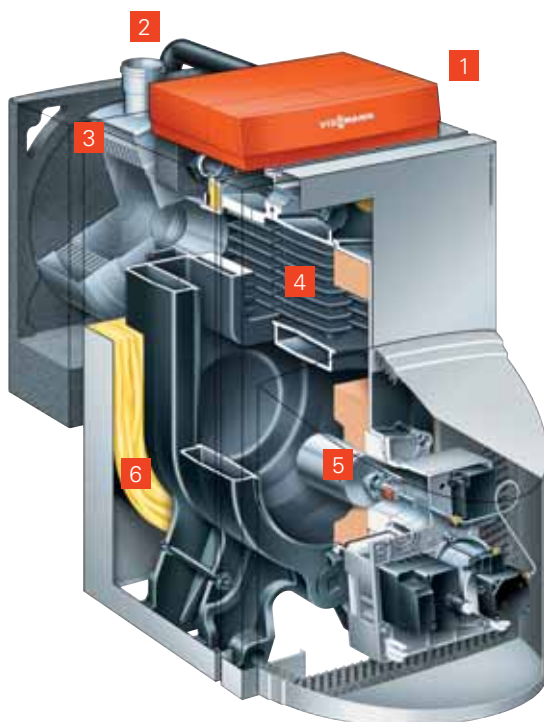

#### VITORONDENS 200-T

- 1** Vitotronic control unit
- 2** Flue gas routing to the top
- 3** Inox-Radial heat exchanger
- 4** Eutectoplex heating surface
- 5** Vitoflame 300 Unit blue flame oil burner
- 6** Highly effective thermal insulation

**VITORONDENS 200-T**  
20.2 to 107.3 kW

The Vitorondens 200-T is a floorstanding cast iron oil condensing boiler with an attractive price/performance ratio. Its dimensions are impressively compact and it is particularly suitable for modernisation projects.

**Clean combustion thanks to the Vitoflame 300 blue flame oil burner**

The Vitoflame 300 Unit blue flame oil burner is designed for all commercially available EL-type fuel oils, and ensures particularly clean, environmentally responsible and efficient combustion. As an option, up to 10 percent bio-oil can be added to the fuel oil.

**Easy and convenient control**

The Vitotronic 200 control unit with plain text display and graphic support enables easy, self-explanatory operation with user prompts. The Vitotronic enables the convenient control of heating systems consisting of one heating circuit without mixer and up to two heating circuits with mixer.



Inox-Radial heat exchanger – durable and efficient



The Eutectoplex heating surface guarantees a long service life and a high degree of operational reliability.

# Specification



## VITOLADENS 300-C

<b>Rated heating output (50/30 °C)</b>				
Modulating	kW	10.3 – 19.3	10.3 – 23.6	12.9 – 28.9
Two-stage	kW	12.9 – 19.3	16.1 – 23.6	19.3 – 28.9
<b>Rated heating output (80/60 °C)</b>				
Modulating	kW	10.0 – 18.7	10.0 – 22.09	12.5 – 28.1
Two-stage	kW	12.0 – 18.0	15.0 – 22.0	18.0 – 27.0
<b>Dimensions</b>				
Length	mm	958	958	1076
Width	mm	638	638	638
Height	mm	1075	1075	1075
<b>Weight</b>				
	kg	148	148	168
<b>Energy efficiency class</b>				
		A	A	A



## VITOLADENS 300-T

<b>Rated heating output (50/30 °C)</b>				
	kW	35.4	42.8	53.7
<b>Rated heating output (80/60 °C)</b>				
	kW	33.0	40.0	50.0
<b>Dimensions</b>				
Length	mm	1585	1770	1770
Width	mm	667	776	776
Height	mm	934	1050	1050
<b>Weight</b>				
	kg	242	333	333
<b>Energy efficiency class</b>				
		A	A	A





**VITORONDENS 200-T**

<b>Rated heating output (50/30 °C)</b>	kW	20.2	24.6	28.6	35.4	42.8	53.7
<b>Rated heating output (80/60 °C)</b>	kW	18.8	22.9	27.0	33.0	40.0	50.0
<b>Dimensions</b>							
Length	mm	1226	1226	1362	1362	1662	1662
Width	mm	500	500	500	500	500	500
Height	mm	940	940	940	940	940	940
<b>Weight</b>	kg	147	147	184	184	224	224
<b>Energy efficiency class</b>		A	A	A	A	A	A



**VITORONDENS 200-T**

<b>Rated heating output (50/30 °C)</b>	kW	67.6	85.8	107.3
<b>Rated heating output (80/60 °C)</b>	kW	63.0	80.0	100.0
<b>Dimensions</b>				
Length	mm	1704	1704	1704
Width	mm	600	600	600
Height	mm	1149	1149	1149
<b>Weight</b>	kg	348	348	348
<b>Energy efficiency class</b>		A	A	A

## System technology ensures reliable and economical operation

The convenient controls and perfectly matched Viessmann system components offer maximum reliability, flexibility and efficiency.

"The whole is greater than the sum of its parts." In accordance with this philosophy, Viessmann does not simply supply individual heating equipment components that meet high standards of quality, reliability and effectiveness. In addition, all products are part of a matching overall concept, where all components complement one another. After all, only perfect interaction between all system parts can draw out the maximum potential of our innovative leading technology.

Viessmann system technology includes everything that makes a reliable and economical heating system: from the Vitotronic control unit with wireless remote control or online operation via app, powerful Vitocell DHW cylinders for the highest DHW convenience, right up to high grade solar thermal systems for cost effective central heating backup and DHW heating.



- 1 Vitoladens 300-C oil condensing boiler
- 2 Vitocell 360-M multi mode combi cylinder for DHW heating and central heating backup with attached Solar-Divicon
- 3 Vitosol 200-FM flat-plate collectors

Energy efficiency class: A  
In combination with solar  
collectors

**A+**



### OPERATING CONVENIENCE

Clear, convenient, intelligent: the Vitotronic offers perfect functionality for fast and precise control of any heating system.



### CONNECTIVITY

With Vitoconnect and a smartphone, the operation of your Viessmann heating system couldn't be easier. Heating systems can be controlled with the ViCare app (page 10/11). All apps are available for mobile devices running iOS or Android operating systems.



### SOLAR THERMAL AND PHOTOVOLTAIC SYSTEMS

Energy from the sun is free, and solar thermal systems deliver hot water for DHW heating and central heating backup. By installing a photovoltaic system, everyone can become their own electricity supplier and use the power they have generated on site.



### DHW CYLINDERS

DHW convenience for every demand: Vitocell DHW cylinders are convenient solutions for supplying a household with hot water – the perfect complement to any oil condensing boiler.



### SYSTEM ACCESSORIES

In addition to high quality Viessmann products, we also offer system components from other well known manufacturers with the Vitoset range of accessories.

Radiators, expansion vessels, pipework systems, pumps, filters and valves – Vitoset offers the complete range of accessories for the Viessmann heating system.



Discover more about the Viessmann radiator range



Find out more about Vitocell



At Viessmann, proximity to trade partners is the basis of the company's success. Everyone who chooses Viessmann heating technology benefits from their expertise.

Property developers and system users can receive advice and support regarding sales, installation and customer service exclusively via Viessmann trade partners, who complete regular training at the Viessmann Academy, and have an in-depth knowledge of the company's products.

Every system user benefits from the comprehensive service that all installation contractors offer as standard.

# With Viessmann trade partners, you're in good hands

## EXAMPLES OF THE SERVICE WE PROVIDE

- Free, no-obligation and individual consultation, even on site
- Clear calculation of heating cost savings after modernisation of the heating system – including systems combined with solar collectors, of course
- Calculation of the payback period, after which the new heating system will have paid for itself through energy savings
- Calculation of the actual heat and DHW demand for your household or property
- Information on the most viable combination of a new heating system with a solar thermal system for central heating backup and DHW heating
- Up to date information about public subsidy programmes that could help to finance a new heating system and a solar thermal system
- Support in applying for subsidies

### Technology from Viessmann – subsidies from the government

You don't just save on running costs. Energy savings and environmentally responsible heating technology is also financially supported by local, regional and national bodies through various subsidies, as well as by power supply utilities [in Germany].

You can find the latest information online at [www.viessmann.de/foerderprogramme](http://www.viessmann.de/foerderprogramme)

or ask your trade partner.



Reliable and competent advice from Viessmann employees and contractors on site and at their offices

### Attractive finance – invest now and save on heating costs immediately

With the Viessmann finance model, you can start saving straight away, and turn your plans into reality. The fast and reliable process, with no red tape, makes modernisation projects easier, allowing your financial planning to remain flexible. The particular advantage is that with Viessmann's favourable terms, savings on heating costs are generally significantly higher than finance costs.

### Please note

Applications for subsidies and finance must be made before the heating and/or solar thermal system is purchased. Subsidies and finance agreements cannot be arranged retrospectively.

### Terms and conditions to shout about

If you invest now in a new heating system for your property, you may be eligible for an attractive finance package from Viessmann in conjunction with CreditPlus bank: just 3.99 percent\* effective APR.

**CreditPlus**

\* Over 24 months

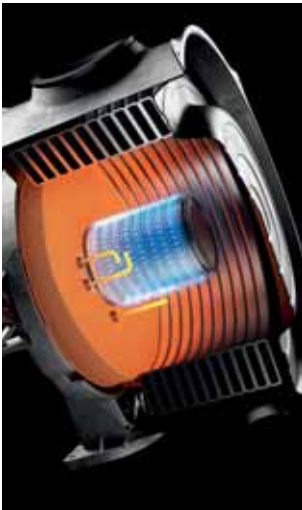

Matrix-Plus burner

#### Viessmann comprehensive range

- Boilers for oil or gas
- Combined heat and power generation
- Hybrid appliances
- Heat pumps
- Wood combustion technology
- Biogas production plants
- Biogas upgrading plants
- Solar thermal
- Photovoltaic
- Electric heating/DHW systems
- Refrigeration systems
- Accessories

#### Milestones of heating technology

As an environmental pioneer and technological trailblazer for the heating sector, Viessmann has been supplying exceptionally clean and efficient systems for heating, refrigeration and decentralised power generation for decades. Many of the company's developments are recognised as heating equipment milestones.

#### Sustainability in action

As a family business Viessmann takes the long view and places great value on acting responsibly; sustainability is firmly enshrined in the company's principles. For Viessmann, sustainability in action means striking a balance between economy, ecology and social responsibility throughout the company; meeting current needs without compromising the quality of life of future generations.

With its strategic sustainability project, Viessmann demonstrates at its own head office in Allendorf (Eder) that the energy and climate policy goals set by the German government for 2050 can in fact be achieved today with the help of commercially available technology.



We create living spaces  
for generations to come.

#### Practical partnership

As part of its comprehensive range, Viessmann also offers a wide selection of complementary services. These services include a comprehensive training and further development programme for trade partners at the well equipped training facilities of the Viessmann Academy.

With its new digital services, Viessmann offers innovative solutions such as the operation and monitoring of heating systems by smartphone. Users benefit from greater reassurance and convenience, whilst contractors can keep a constant eye on the systems for which they are responsible.



Number 1 Trade Partner for the 15th consecutive time



Viessmann is a leading international manufacturer of efficient energy systems.

#### VISSMANN GROUP IN FIGURES

1917

— Viessmann was founded

12,000

— employees

2.5

— Group turnover in billions of euros

54

— export share in percent

23

— production companies in

12

— countries

120

— sales offices worldwide

74

— countries with agents and sales companies



Viessmann Werke GmbH & Co. KG  
35107 Allendorf (Eder)  
Germany  
Telephone +49 (0)6452 70-0  
[www.viessmann.com](http://www.viessmann.com)

**Your trade partner**

9449 578 - 10 GB 04/2019

Copyright Viessmann.  
Duplication and alternative use  
only with prior written consent.  
Subject to modifications.

---